

009B

Tubular Key Duplicator

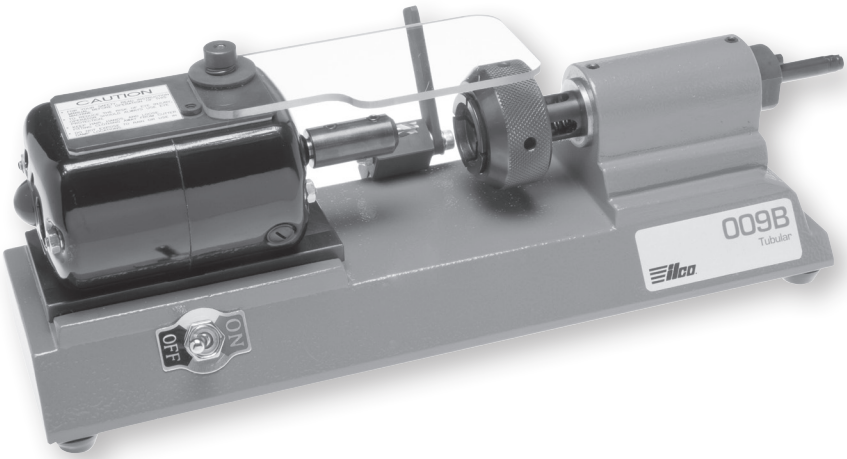

OPERATION MANUAL

The 009B Tubular Key Machine is a precision tool and should be operated with care. Please read this instruction manual before duplicating any keys. This manual gives step by step instructions on how to duplicate tubular keys and includes a section on how to adjust the 009B.

CONTENTS

How to Duplicate a Key	
How to Replace the Cutter	
How to Make Cutter Adjustments	
Limited Warranty	

The 009B is designed for duplicating the Ilco® 1137B tubular style key. Examine the diagram and familiarize yourself with the Tubular Key Machine. Knowing the names for the basic parts of this machine will make instructions more meaningful and easier to understand.

Parts

A	Motor
B	Cutter Adapter
C	Cutter
D	Chuck Nut (Closing Nut)
E	Clear Shield
F	Guide
G	Main Shaft
H	Shield Knob
I	Power Switch
J	Key Gauge

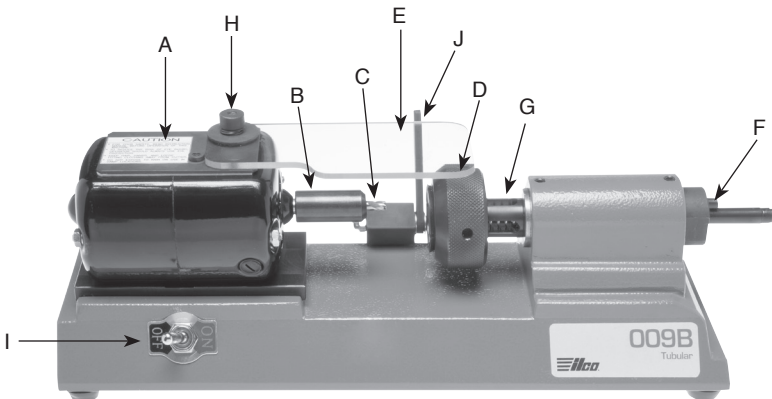

How to Duplicate a Key

1. Place original key (key being duplicated) on end of shaft to right of machine. (See Figure A)
2. Insert key blank (uncut key) into chuck end of main shaft making certain that the key blank indexing is in the same direction as the original key.

Index (nib) on both key blank and original must face up. (See Figure B)

The key blank should be bottomed in the chuck. Partially tighten chuck.

3. Rotate Key Gauge into the “load” position, and then loosen the Main Shaft Closing Nut to allow the key blank to position against the face of the Setting Gauge. **Tighten the Closing Nut to retain the key blank in this position.** (See Figure C) Now rotate the Key Gauge back into its “rest” position.

4. Swing the Clear Safety Shield into position above the cutter as shown in Figure D. Turn the Power Switch “ON”.
5. Advance the original key and at the same time rotate so that the first cut on the original key lines up with the guide. Advance key slowly until the guide bottoms firmly in the cut. Back off slowly and rotate key to next cut. Repeat this process until all cuts are completed. (See Figure E)

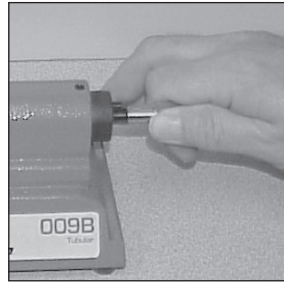

Fig. A

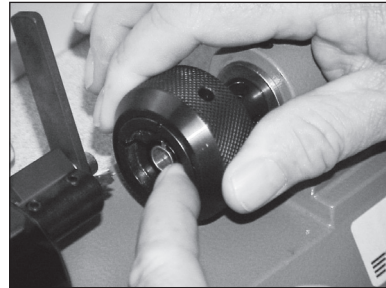

Fig. B

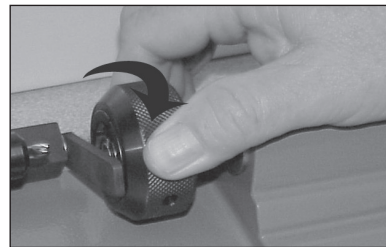

Fig. C

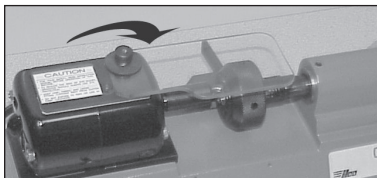

Fig. D

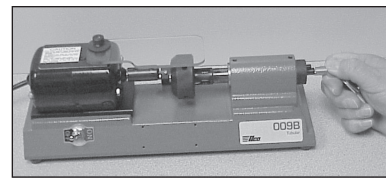

Fig. E

6. Turn power switch “OFF” and swing clear shield to “load” position.
7. Loosen chuck closing nut and remove key.

Caution: In order to prolong cutter life, a slow steady movement should be maintained while cutter is in contact with key blank. We do not recommend cutting steel key blanks as cutter life will be dramatically reduced.

How to Replace the Cutter

The cutter should be replaced when cuts begin to look rough or undue force is required for the cutter to cut the key blank. Do not attempt to cut keys when the cutter is dull. The proper cutter for use on the 009B is Ilco® part #16TW.

Caution: Machine should be unplugged when replacing the cutter or making any cutter adjustments.

1. Place an **1137B** key blank on shaft to right of machine.

2. Insert a second blank into the Main Shaft chuck until bottomed out flush with the face of the chuck. (See Figure F) Tighten closing nut lightly to retain in this position.

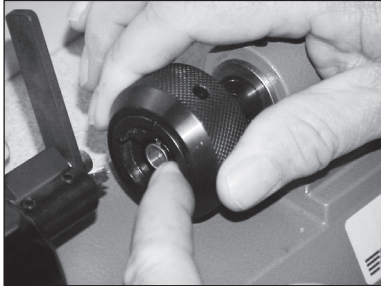

Fig. F

3. Rotate Key Gauge into the "load" position, and then loosen the Main Shaft Closing Nut to allow the key blank to position against the face of the Key Gauge. **Tighten the Closing Nut to retain the key blank in this position.** (See Figure G) Now rotate the Key Gauge back into its "rest" position. See Figure .

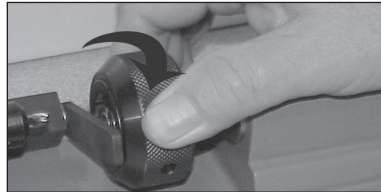

Fig. G

4. Remove dull cutter by loosening cutter adapter set screw and removing cutter. (See Figure H)

5. Insert new cutter (part #16TW), leaving approximately 1/2 inch of the cutter exposed. (Don't tighten set screw yet.)

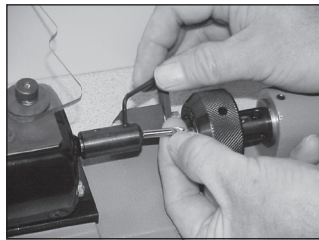

Fig. H

6. Holding key blank in place on end of shaft, advance key toward cutter until it comes to rest against the guide. During this process, the key blank which you have placed in the chuck will have pushed the cutter into proper position. (See Figure I)

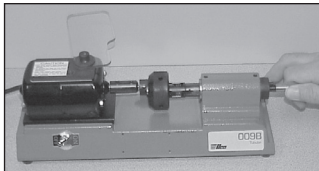

Fig. I

7. Tighten cutter adapter set screw to secure the cutter in this position, taking care not to disturb the positioning of the cutter. The machine is now ready for use.

How to Make Cutter Adjustments

Cutter Height (Wall Thickness)

Check cutter height by cutting sample key and measuring the distance across the cuts with dial calipers.

If this dimension is not within the proper range, the cutter height must be adjusted. This dimension may range from .323 inch to .328 inch (A). (See Figure J)

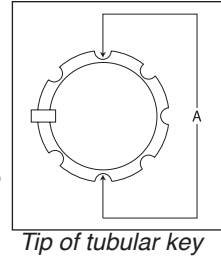

Fig. J

If adjustment is needed:

1. Unplug the machine!
2. Using a Phillips type screwdriver, remove the four rubber feet from the bottom of the machine to release the machine's bottom cover plate. (See Figure K)
3. Slightly loosen the motor elevation locking screw (A)*. (See Figure L)

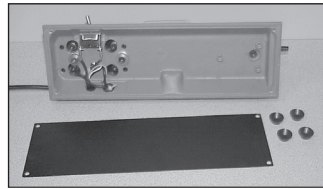

Fig. K

* **Very Important! Do not loosen or adjust screws identified in the photo as "X"**

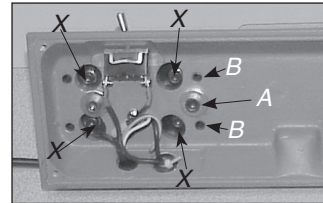

Fig. L

- If cuts are not deep enough (measurement more than .328"), back off (counter-clockwise) both adjustment screws (B). Be certain to back off both screws exactly the same amount. Each 1/16 turn will lower the cutter approximately .010 inch.
 - If cuts are too deep (measurement less than .323"), advance (clockwise) both adjustment screws (B). Be certain to advance both screws exactly the same amount. Each 1/16 turn will raise the cutter approximately .010 inch.
4. Tighten motor elevation locking screw (A). Cut another key. Measure distance across the cuts and repeat steps given above if necessary.
 5. Reposition bottom cover and re-attach rubber feet.

Limited Warranty

Kaba Ilco warrants to the original buyer of any new model 009B machine that it will repair or replace, at its option, any part of any machine which proves, to the reasonable satisfaction of Kaba Ilco to have defects arising from the quality manufacture of the machine or from defective materials or components, during a period of one year from the date of shipment of the machine by Kaba Ilco, provided that the machine is returned by prepaid transport to Kaba Ilco or to its authorized representative before the expiry of the warranty period together with a detailed description of the alleged defect(s). Kaba Ilco, may, in its discretion, elect to refund the purchase price allocable to the part affected, or to issue a credit if the price therefore remains unpaid.

Kaba Ilco sells precision-made machines. The buyer assumes all risks and Kaba Ilco shall not be liable for any reason, if the machine has been subjected to improper installation, improper use, improper or inadequate maintenance, negligence, of any unauthorized modification or alteration is made to the machine not operated in accordance with Kaba Ilco's printed instructions or operated beyond its rated capacity shall not be covered by this or any other warranty,

Any and all warranties made by Kaba Ilco to any machine, product, or component thereof shall be effective only if and for so long as the buyer complies with all payment obligations pursuant to the buyer's accepted and acknowledged order. Failure to meet such payment obligations pursuant to the buyer's accepted and acknowledged order. Failure to meet such payment obligations shall void all warranties and not extend the period of time for which such machine, product or component thereof is warranted irrespective of whether or not payment is eventually made.

These warranties are in lieu of and not in addition to any other warranty of condition, expressed or implied including without limitation merchantability, fitness for a particular purpose or latent defects. The buyer releases Kaba Ilco from any liability for any reason other than a breach of its warranties hereunder.

The liability of Kaba Ilco shall in no case, including negligence, exceed the purchase price of the defective machine, nor shall Kaba Ilco be liable for an personal injuries, property damage or consequential damages.

Use only genuine Kaba Ilco replacement parts on this machine.

Kaba Ilco Corp.
400 Jeffreys Road • Rocky Mount, NC 27804
Phone **800.334.1381** • Fax **252.446.4702**
www.kaba-ilco.com

Code No. 125146